

*Technical Documentation
for KSF High Precision Power Chucks*

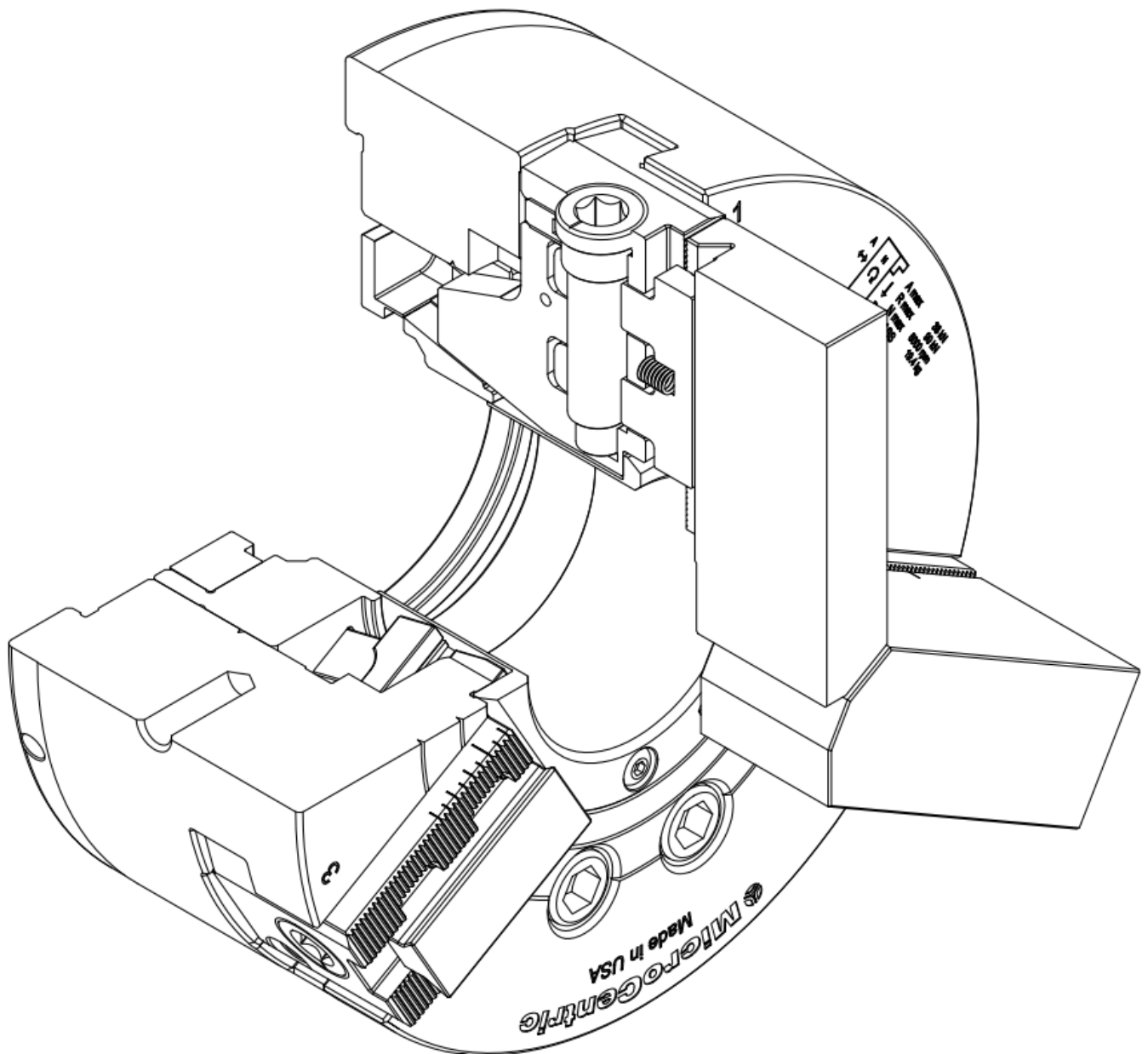

TABLE OF CONTENTS

1.0 Contact & Service Information	2
2.0 Introduction	3
3.0 Precautions for Safe Operation	4
4.0 Recommended Tightening Torque for Mounting Screws	8
5.0 Precision Power Chuck Specifications	9
6.0 Maximum Clamping Force and Spindle Speed	10
6.1 Maximum Static Clamping Force	12
6.2 Maximum Recommended Speed	10
6.3 Effects of Centrifugal Force	10
7.0 Design and Machining of Top Jaws	11
7.1 Top Jaw Design	11
7.2 External Chucking Top Jaws	12
7.3 Internal Chucking Top Jaws	12
7.4 Machining Top Jaws	13
8.0 Precision Power Chuck System Assembly	14
9.0 Mounting of Chuck	15
9.1 Mounting Adapter Plate	15
9.2 Mounting Chuck Assembly	15
10.0 RC Jaw Locating System	16
10.1 RC System Overview	16
10.2 RC Jaw Installation	16
11.0 QC Jaw Locating System	17
11.1 QC System Overview	17
11.2 QC Jaw Installation	17
11.3 QC Jaw Removal	17
12.0 Assembly Drawing and Parts List	18
12.1 KSF-08/RC & KSF-10/RC Assembly and Parts List	18
12.2 KSF-08/QC & KSF-10/QC Assembly and Parts List	19
13.0 KSF Chuck Maintenance	20
13.1 Lubricating KSF Chucks	20
13.2 Frequency of Lubrication	20
13.3 Disassembly of KSF Chucks	20
13.4 Cleaning of KSF Chucks	21
13.5 Reassembly of KSF Chucks	21
14.0 Trouble Shooting Guide	22

1.0 CONTACT AND SERVICE INFORMATION

Manufactured by:
MicroCentric Corp.
Plainview, NY USA
www.microcentric.com

Service in North America:
MicroCentric Corp.
25 South Terminal Drive
Plainview, NY 11803 USA
Phone: 1-516-349-7220
E-mail: sales@microcentric.com







Service in Europe:
MicroCentric GmbH
Ringstrasse 134
70839 Gerlingen
Germany
Phone: 49-71156-17819-00
E-mail: info@microcentric.de

Service in Asia:
Dynamic Tools Corp.
7-4-6 Seikadai, Seika-cho
Sorakugun
Kyoto 6190238 Japan
Phone: 81-774-98-0518
E-mail: dynex@earth.email.ne.jp

2.0 INTRODUCTION

The ultimate High Precision Power Chuck, KSF Series chucks offer unmatched accuracy and long term performance. Their advanced design, high quality hardened alloy steels, and MicroCentric's renowned precision manufacturing capability result in a chuck of unmatched quality.

The information contained in this manual, if properly followed, will enable you to obtain the best possible accuracy and long term performance from your KSF chuck. This manual is also available for download at microcentric.com.

	SAFETY ALERT SYMBOL
	This symbol is used to call attention to items that could be dangerous to you or persons using this equipment. Please read these messages and follow these instructions and safety regulations before use.
	 DANGER
	Indicates an imminent hazardous condition which, if not avoided, could result in serious injury or death.
	 WARNING
	Indicates a potentially hazardous condition which, if not avoided, could result in serious injury or death.
	 CAUTION
	Indicates a potentially hazardous condition which, if not avoided, could result in injury.
	IMPORTANT
	Instructions for optimum performance and avoiding errors or misuse of chuck.

3.0 PRECAUTIONS FOR SAFE OPERATION



DANGER



Switch off power to the machine before installing or changing the chuck.

- The machine spindle may inadvertently be switched on, and the turret indexed or jogged, potentially causing serious injury to the operator.



DANGER



Do not operate the control valve (foot pedal) or solenoid valve during spindle rotation.

- The workpiece will be thrown from the chuck, potentially causing serious injury to the operator.



DANGER



Do not exceed maximum recommended speed of the chuck for a given input pressure.

- The workpiece can be thrown from the chuck due to inadequate gripping force as a result of centrifugal force.



DANGER



Never wear gloves, loose clothing, or ties while operating a machine tool. Secure long hair.

- Gloves, loose clothing, ties, and long hair can become caught in the chuck causing serious injury to the operator as the spindle is rotated.



DANGER



Always lift the chuck by using an eyebolt or lifting belt, and stand clear of suspended loads.

- The operator can be injured and the chuck can be damaged if the chuck is dropped.



WARNING



Do not start the machine with the door open.

- The operator could be injured by cutting chips or other flying debris.



WARNING



Do not exceed the maximum recommended input force (draw tube force) for a specific chuck model.

- The workpiece can be thrown from the chuck as a result of damage to the chucks actuating mechanism.



WARNING



Make certain the mounting bolts are securely tightened to the recommended torque values.

- The chuck could become loose during operation causing damage to the chuck and potentially throwing the workpiece from the chuck.



WARNING



Never attempt to operate a machine tool while under the influence of drugs or alcohol.

- Damage to the machine, tooling, and chuck, or serious injury to the operator could result.



WARNING



Remember to lubricate the chuck at regular intervals as specified in this manual.

- The workpiece can be thrown from the chuck due to a loss of gripping force caused by insufficient lubrication.



WARNING



Do not attempt to modify the chuck.

- The workpiece can be thrown from the chuck due to damage which may be caused to the chuck.



WARNING



Long workpieces should be supported by a live center in the tail stock or by a steady rest.

- The workpiece can be thrown from the chuck if it is too long and not properly supported.



WARNING



Remove eyebolts after use.

- Rotating the chuck without removing eye bolts may cause them to be thrown from the chuck, potentially causing serious injury.



WARNING



Disassemble and clean chuck according to Section 12.0.

- Failure to properly disassemble and clean the chuck can lead to insufficient clamping force, and the workpiece can be thrown from the chuck.



CAUTION



Ensure workplace is clean.

- Danger of slipping and falling from a dirty floor, such as lubricants or oil.



CAUTION



Always make sure to keep your hands and fingers clear of the top jaws and workpiece as the chuck is clamped.

- The operator can be seriously injured if a finger or hand is clamped between the top jaw and the workpiece.

CAUTION



Do not touch machined workpieces with bare hands.

- Machined workpieces may be very hot, and may cause burns.

CAUTION



Remove workpiece when stopping the machine for an extended period of time.

Clamping force may be lost unexpectedly, causing the workpiece to drop.

CAUTION



Never hit the outside of the chuck, top jaws, or workpiece with a hammer.

- The workpiece can be thrown from the chuck if the chuck is damaged.

4.0 RECOMMENDED TIGHTENING TORQUE FOR MOUNTING SCREWS

SOCKET HEAD CAP SCREW SIZE (CLASS 12.9)	M5	M6	M8	M10	M12	M14	M16	M20
TIGHTENING TORQUE [N*m]	7.5	13	33	73	107	171	250	402
TIGHTENING TORQUE [lb*ft]	5.5	9.6	24	54	79	126	184	297

5.0 PRECISION POWER CHUCK SPECIFICATIONS

5.1 RC RAPID CHANGE SPECIFICATIONS

Chuck Model	KSF-08/RC	KSF-10/RC
Jaw System	Rapid Change	Rapid Change
Number of Jaws	3	3
Repeating Accuracy	0.0004" 0.01mm	0.0004" 0.01mm
Through Hole Diameter	2.598" 66mm	3.228" 82mm
Jaw Stroke (on diameter)	.299" 7.6mm	.355" 8.5mm
Actuator Stroke	.709" 18mm	.787" 20mm
Max Draw Tube Force	8,540 lbs 38 kN	11,240 lbs 50 kN
Max Clamping Force	21,130 lbs 94 kN	26,970 lbs 120 kN
Max Speed	5,000 rpm	4,500 rpm
Chuck Weight	52.0 lbs 23.6 kg	88.2 lbs 40.0 kg
Moment of Inertia	16.8 lb-ft 6.9 N-m	30.6 lb-ft 12.7 N-m

5.2 QC PRECISION CHANGE SPECIFICATIONS

Chuck Model	KSF-08/QC	KSF-10/QC
Jaw System	Precision Change	Precision Change
Number of Jaws	3	3
Repeating Accuracy	0.0001" 0.0025mm	0.0001" 0.0025mm
Through Hole Diameter	2.598" 66mm	3.228" 82mm
Jaw Stroke (on diameter)	.299" 7.6mm	.355" 8.5mm
Actuator Stroke	.709" 18mm	.787" 20mm
Max Draw Tube Force	8,540 lbs 38 kN	11,240 lbs 50 kN
Max Clamping Force	21,130 lbs 94 kN	26,970 lbs 120 kN
Max Speed	5,000 rpm	4,500 rpm
Chuck Weight	52.0 lbs 23.6 kg	88.2 lbs 40.0 kg
Moment of Inertia	16.8 lb-ft 6.9 N-m	30.6 lb-ft 12.7 N-m

6.0 MAXIMUM CLAMPING FORCE AND SPINDLE SPEED

6.1 MAX. STATIC CLAMPING FORCE

The static clamping force developed by KSF chucks will vary depending on several variables including the state of lubrication of the chuck, the type of grease used, the height of the top jaws, among other factors. MicroCentric's standard specifications for KSF chucks are based on the following conditions:

1. A standard height top jaw is used.
2. Jaw force is measured at the mid point (in height) of a standard jaw blank, at mid stroke with a jaw force gage.
3. MicroCentric's recommended grease is used to obtain maximum efficiency of the chuck.
4. The recommended draw tube force is applied to the chuck.

6.2 MAX. RECOMMENDED SPEED

The maximum recommended speed for KSF chucks is defined as the speed at which the measured clamping force during rotation is reduced by 2/3 of the static value. Dynamic clamping force is measured under the following conditions:

1. A standard jaw height is used.
2. Jaw force is measured at the mid point (in height) of a standard jaw blank, at mid stroke with a dynamic jaw force gage.
3. The chuck is sufficiently lubricated with MicroCentric's recommended grease to obtain maximum efficiency of the chuck.
4. The maximum recommended draw tube force is applied to the chuck.

6.3 CENTRIFUGAL FORCE

Centrifugal force acts on the chuck jaws during rotation. It is important to always reduce the weight of the top jaw as much as possible for each application to minimize the effects of centrifugal force, and consequently, the loss of clamping force during rotation.

IMPORTANT

Always reduce the weight of the top jaw as much as possible to minimize the clamping force loss as the chuck rotates.

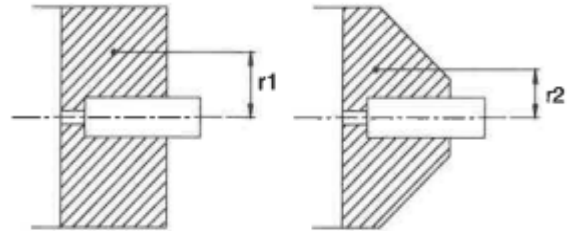

Standard Top Jaws

Top Jaws With Excess Weight Removed



CAUTION

When using top jaws which are taller and more massive than the standard jaw, a greater amount of clamping force will be lost due to centrifugal force which acts on the top jaw. The maximum recommended speed under these conditions will be less than the value for the standard top jaws.

7.0 DESIGN AND MACHINING OF TOP JAWS

7.1 TOP JAW DESIGN

Top jaw design is one of the most important elements in the overall performance, accuracy, and efficiency of a workholding system. To achieve the maximum possible accuracy, as well as optimize the chuck's clamping capability, the following points should be considered in the design and machining of top jaws.

1. A workpiece must have an accurately machined holding diameter, in terms of size tolerance, roundness, and perpendicularity to the locating surface, for precise chucking.
2. When chucking thin walled workpieces, the size and roundness tolerances of the holding diameter will determine the degree to which the workpiece is distorted during chucking, and how accurately the workpiece can be machined.
3. The workpiece should be clamped as close to the face of the chuck as possible.
4. The clamping surfaces of the workpiece and top jaws must have smooth surface finishes, and must be absolutely clean and free of burrs.
5. For external clamping applications, the mass of the top jaws should be reduced as much as possible to minimize the effects of centrifugal force. It is especially important to reduce weight at the largest radius. Refer to Figure 7.1.

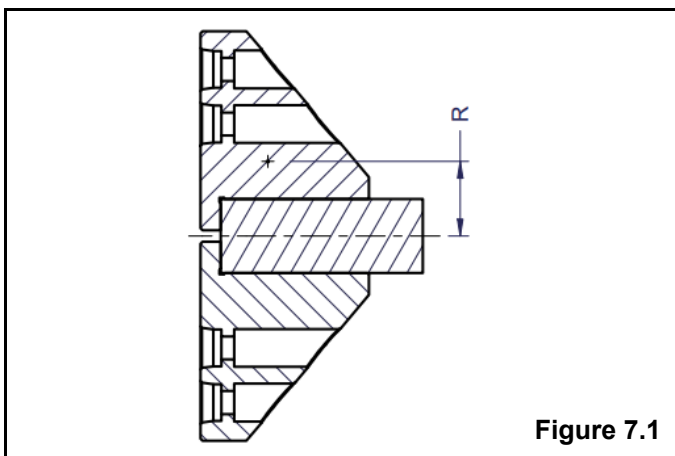

Figure 7.1

6. Short workpieces must have a square locating face on which they are banked, in order to ensure the part is clamped accurately. Refer to Figure 7.2.

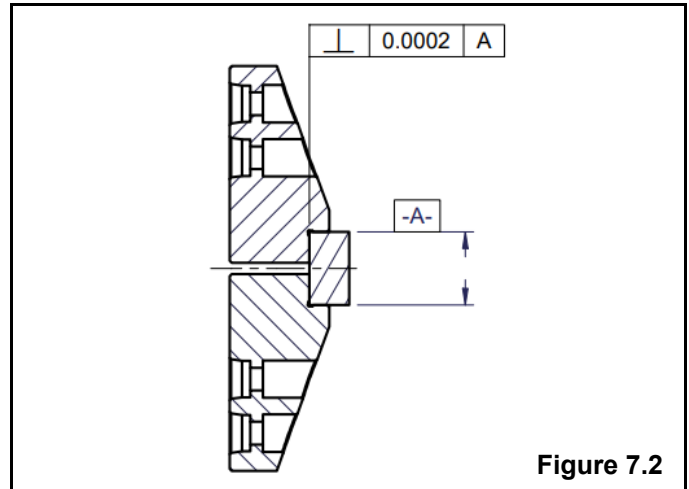

Figure 7.2

7. Workpieces with no shoulder support must be clamped on a length twice their diameter. Refer to Figure 7.3.

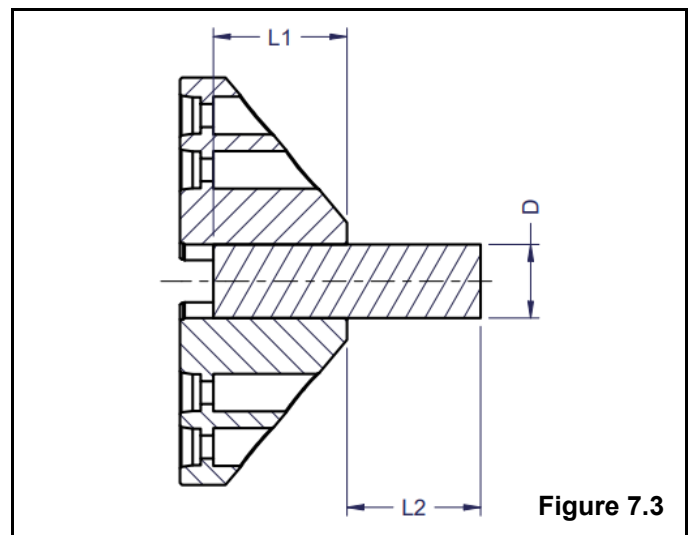

Figure 7.3

8. Long workpieces should not extend beyond the face of the top jaws more than one and one half times the length being clamped, unless an end support is used. Refer to Figure 7.3.

9. In situations where the top jaws' counter bored mounting bolt holes interfere with the clamping diameter, it is very important that the top jaw's clamping diameter is machined to the exact diameter of the workpiece diameter. Otherwise two-line contact occurs during clamping as shown in Figure 7.4, which will result in a loss of chucking accuracy.

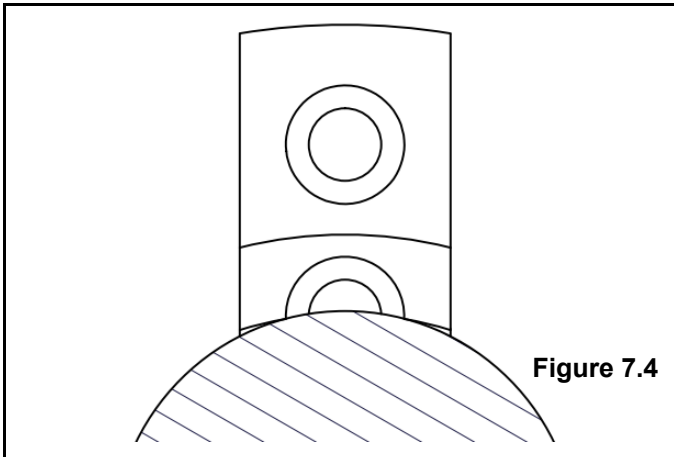

Figure 7.4

7.2 EXTERNAL CHUCKING TOP JAWS

1. For external chucking applications, the clamping diameter of the top jaws should be equal to or slightly larger than the upper tolerance limit of the workpiece's clamping diameter.
2. When the workpiece's clamping diameter is smaller than the top jaws' clamping diameter, line contact occurs during clamping as illustrated in Figure 7.5. This condition is acceptable and will produce accurate and concentric workholding.
3. If the workpiece's clamping diameter is larger than the top jaw's clamping diameter, a two-line contact occurs during clamping as shown in Figure 7.6. This condition is beneficial for high clamping force applications, but usually results in a loss of chucking accuracy.

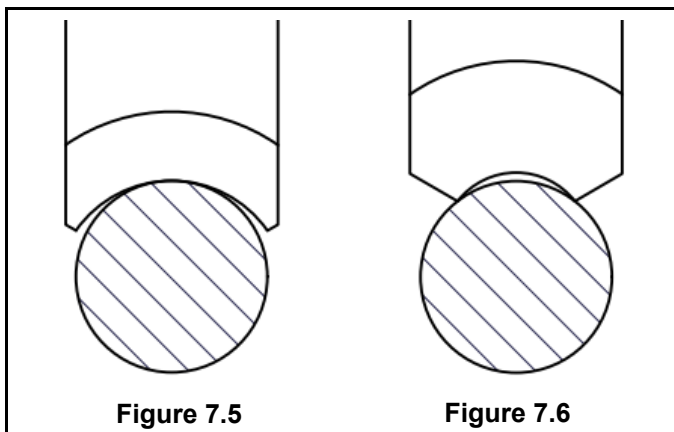

Figure 7.5

Figure 7.6

7.3 INTERNAL CHUCKING TOP JAWS

1. For internal clamping applications, the clamping diameter of the top jaws should be equal to or smaller than the lower tolerance limit of the workpiece's clamping diameter.
2. When the workpiece's clamping diameter is larger than the top jaws' clamping diameter, a line contact occurs during clamping as shown in Figure 7.7. This condition is acceptable and will produce accurate and concentric workholding.
3. If the workpiece's clamping diameter is smaller than the top jaws' clamping diameter, two line contact occurs during clamping as shown in Figure 7.8. This condition is beneficial for high clamping force applications, but results in a loss of chucking accuracy.

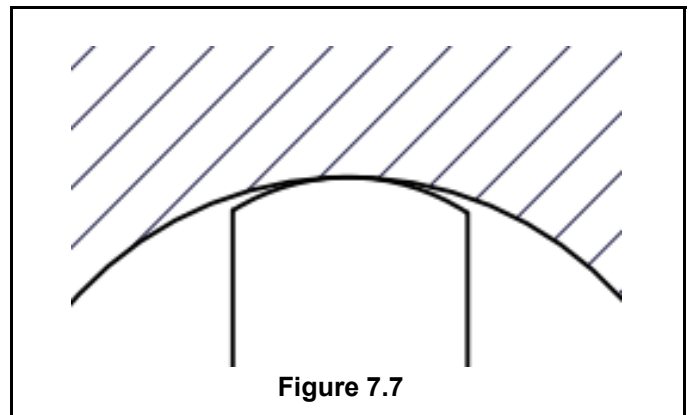

Figure 7.7

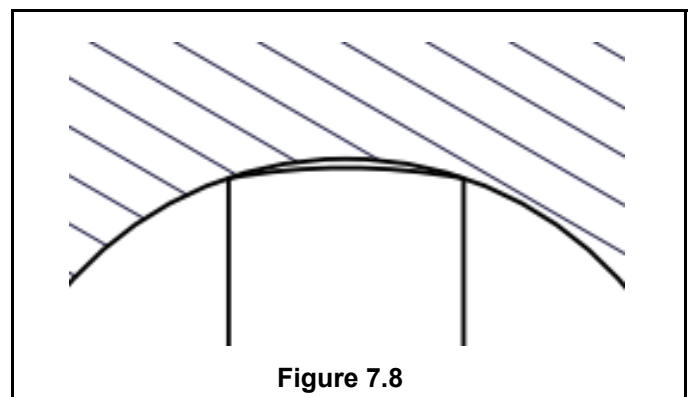
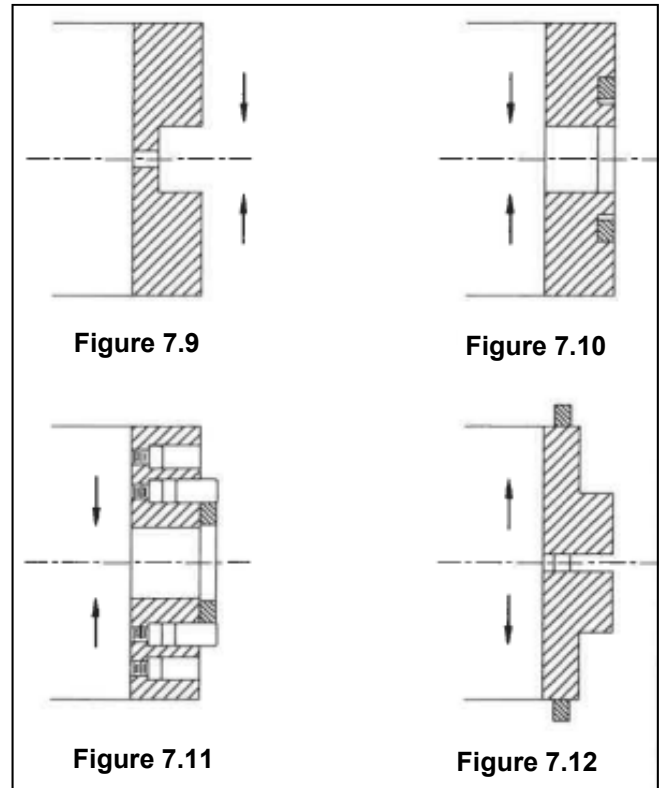

Figure 7.8

7.4 MACHINING OF TOP JAWS

To achieve the best possible chucking accuracy, it is necessary to finish machine the clamping diameter and locating face of the top jaws on the chuck, under load. The method by which the jaws are loaded, together with the surface finish of the clamping and locating surfaces, as well as the size of the clamping diameter, will determine the overall accuracy and clamping capability of the chuck. Consider the following when machining top jaws:

1. Always load the chuck in the same direction the chuck is clamping. For OD holding applications the chuck must be closed on a loading pin or ring. For ID applications the chuck must open on a loading ring.
2. The position at which the chuck is loaded during machining of the top jaws, determines the position within the total stroke of the chuck that the workpiece will be clamped. Top jaws should be machined at the upper end of the chuck's stroke (closer to full open) to permit re-boring of the jaws. Re-boring of the jaws can be accomplished by loading the chuck further down in the stroke with a smaller diameter pin or ring.
3. Loading the top jaws further down in the chuck's stroke (near fully closed) allows greater clearance for applications where the workpiece is automatically loaded. An opening of .040" (1mm) on diameter is recommended for automatic loading.
4. Top jaws should be machined at the same hydraulic/air pressure which will be used to clamp the workpiece during production. In instances where either the loading ring or the top jaws are subject to deflection during loading, it is recommended that the top jaws be machined at a hydraulic/air pressure lower than that to be used during production.
5. Several recommended loading configurations are illustrated in Figures 7.9, 7.10, and 7.11 for OD clamping applications and 7.12 for ID clamping. The loading configuration shown in 7.10 should not be used with top jaws exceeding 2.00" (50mm) in height.
6. Carefully clean the mounting surfaces of the master jaws and top jaws before mounting the top jaws to the chuck. The top jaws should fit snugly on the locating pins or QC buttons. On dowel pin located jaws, first tighten the jaw mounting screws lightly, then clamp the loading pin or ring several times with light air pressure to assure that the top jaws are



7. Top jaws can be rough machined on a turning fixture, but should be finish machined under load on the chuck to achieve best chucking accuracy.
8. Dowel pin located top jaws must be re-machined when they are reinstalled on the chuck to achieve best chucking accuracy.
9. When top jaws are finished on a machine other than the one used in production, it is necessary to establish a true reference diameter and face which is to be indicated when mounting the chuck.

8.0 KSF PRECISION POWER CHUCK SYSTEM ASSEMBLY

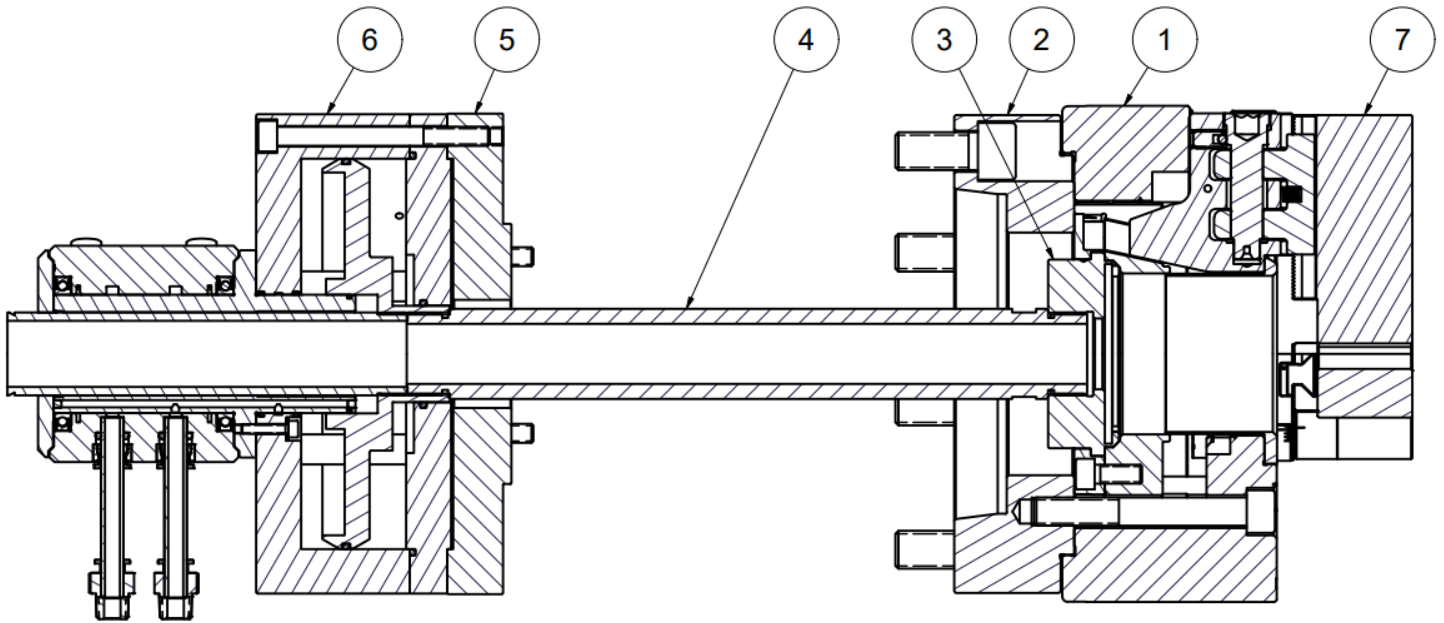

ITEM	QTY	TITLE
1	1	POWER CHUCK
2	1	ADAPTER
3	1	DRAW TUBE CONNECTOR
4	1	DRAW TUBE/BAR
5	1	CYLINDER ADAPTER
6	1	ACTUATOR (HYDRAULIC OR PNEUMATIC)
7	3	TOP JAW BLANK

9.0 MOUNTING OF CHUCK

KSF chucks are supplied with a mounting plate and threaded draw tube connector to suit the machine configuration specified when the chuck was ordered. Refer to the chuck assembly drawing (on pages 18 and 19) to familiarize yourself with the chuck's components before mounting the chuck.

9.1 MOUNTING ADAPTER PLATE

1. Make certain that the spindle and mounting plate are clean and free of nick, burrs, and foreign materials which would prevent the proper seating of the adapter plate.
2. Mount the adapter plate to the machine spindle. Do not fully tighten the mounting bolts at this time. First indicate the radial runout of the pilot diameter, and lateral runout of the mounting face as described in step 3.
3. Use a dial indicator to measure the radial and lateral runout of the mounting surfaces of the adapter plate. Both radial and face runout should not exceed .0002" (0.010mm). Adjust the radial runout to within .0002" (0.010mm) before fully tightening the mounting bolts. If the face runout exceeds .0002" (0.010mm), remove the adapter from the spindle nose and verify that the adapter plate is seating properly and is clean and free of nicks and burrs. A skim cut can be taken on the mounting face of the adapter once it is mounted to the spindle to assure the face is running true.
4. Tighten the mounting bolts alternately to the torque specifications given in Section 4.0.

9.2 MOUNTING CHUCK ASSEMBLY

1. Verify that the draw tube pressure is set to a value within the chuck's limit, adjust draw tube pressure if necessary, and actuate the draw tube to bring it into the forward position.
2. Thread the draw tube connector onto the draw tube. Thread the connector fully onto the draw tube then back off the thread until the detents are fully engaged.
3. Actuate the draw tube to seat the chuck onto the adapter plate, aligning the mounting bolts in the body with the mounting holes on the adapter plate.

4. Tighten the mounting bolts alternately but do not fully tighten them at this point.
5. Indicate the OD of the chuck body and adjust the runout to within .0002" (0.005mm) TIR.
6. After the runout of the chuck's OD has been adjusted, tighten the mounting bolts to the torque specifications given in Section 4.0.
7. Actuate the draw tube to verify that the chuck is functioning properly by measuring the stroke of each jaw. If the jaws do not make their full stroke, check that the draw tube is not being restricted, the draw tube data that was specified when the chuck was ordered is correct, or that the draw tube connector was correctly manufactured.

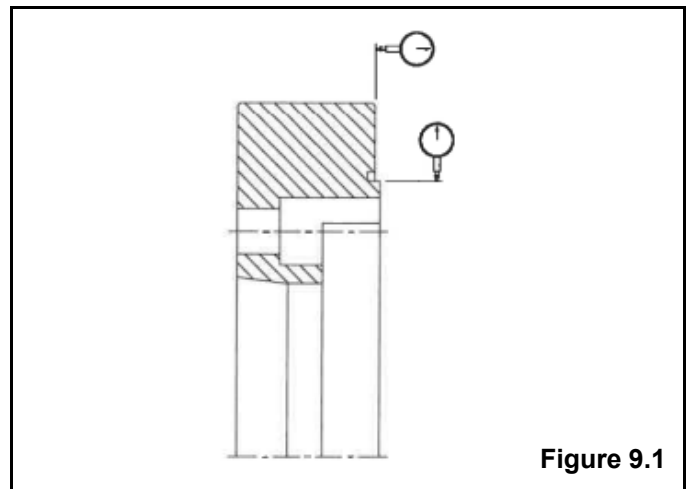

Figure 9.1

IMPORTANT

The runout of the mounting plate should not exceed .0002" (.010mm) radially, and .0001" (.005mm) laterally. The runout of the OD of the chuck body should not exceed .0002" (.010mm).

10.0 RAPID CHANGE JAW LOCATING SYSTEM

10.1 RC SYSTEM OVERVIEW

The RC system locates each top jaw on serrations on each master jaw. The top jaw is held securely to the master jaw by a cam-operated t-nut, and effectively eliminates any clearances between the master jaw and the top jaw. This feature assures accurate relocation of the top jaw when repositioned on the chuck. RC top jaws can also be fixed at varying locations on the master jaws, for either OD clamping, ID clamping, or both.

10.2 RC JAW INSTALLATION

1. First make sure that the locating surfaces of the top jaws and master jaws are completely clean and free from nicks, burrs, or any foreign matter which would prevent proper seating of the top jaws.
2. It is advised that each finished top jaw be stamped or marked 1, 2, and 3 so that they can be mounted to the correspondingly marked master jaw for later reference.
3. Mount the top jaw no. 1 onto master jaw no. 1.
4. Align the marking on the side of the top jaw with the corresponding marking on the side of the master jaw.
5. Use a torque wrench, with a maximum torque of 140 N*m (103 ft*lbs), to adjust the cam and secure the top jaw to the master jaw.
6. Repeat this procedure for the other top jaws.

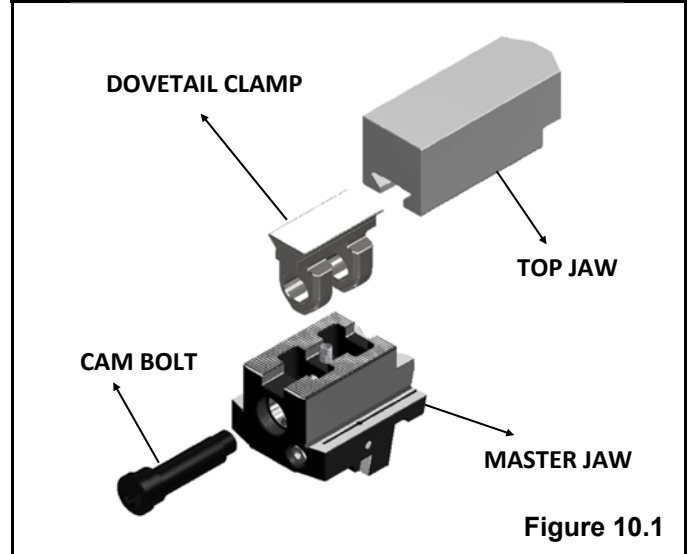

IMPORTANT

The mounting surfaces of the top jaws and master jaws must be clean and be free of nicks or any foreign matter, otherwise the top jaws will not seat properly which will result in excessive runout.



CAUTION

In order to minimize jaw runout, it is critical that the mounting screws of the top jaws are tightened to the torque specifications given in Section 4.0

11.0 QUICK CHANGE JAW LOCATING SYSTEM

11.1 QC SYSTEM OVERVIEW

The QC system locates each top jaw on two tapered buttons mounted in each master jaw. The top jaw is located on both the taper and the face of the master jaw to effectively eliminate any clearances between the master jaw and the top jaw. This feature assures accurate relocation of the top jaw when repositioned on the chuck.

11.2 QC JAW INSTALLATION

1. First make sure that the locating surfaces of the top jaws, master jaws, and QC buttons are completely clean and free from nicks, burrs, or any foreign matter which would prevent proper seating of the top jaws.
2. It is advised that each top jaw be stamped or marked 1, 2, and 3 so that they can be mounted to the correspondingly marked master jaw for later reference.
3. Mount the top jaw no. 1 onto master jaw no. 1.
4. Insert the mounting screws into the top jaw and tighten each screw to the torque specifications given in Section 4.0.
5. Repeat this procedure for the other top jaws.

11.3 QC JAW REMOVAL

1. First loosen the mounting screws from jaw no. 1 and then remove the screws completely from the top jaw.
2. The top jaw may remain locked onto the tapered buttons on the master jaw. To break the top jaw free, tap the end of the top jaw lightly with a soft hammer. Tap the jaw toward the center of the chuck while holding the sides of the top jaw.
3. Repeat this procedure for the other top jaws.

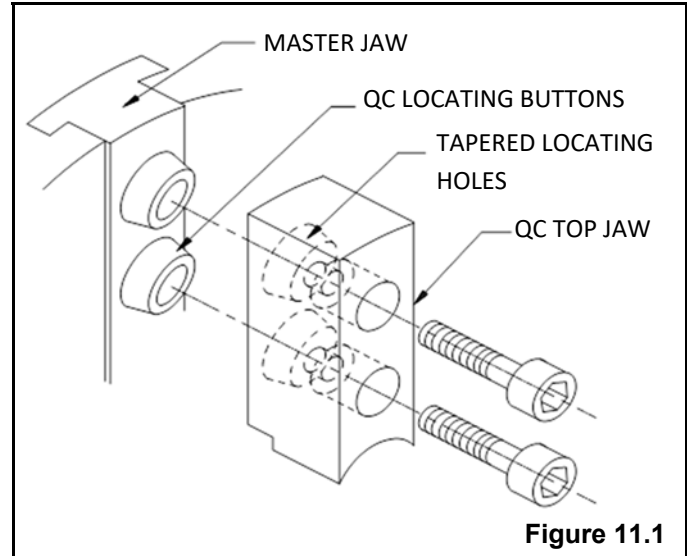

IMPORTANT

The mounting surfaces of the top jaws, master jaws, and QC buttons must be clean and be free of nicks or any foreign matter, otherwise the top jaws will not seat properly which will result in excessive runout.



CAUTION

In order to minimize jaw runout, it is critical that the mounting screws of the top jaws are tightened to the torque specifications given in Section 4.0

12.0 KSF ASSEMBLY DRAWING AND PARTS LIST

12.1 KSF-08/RC & KSF-10/RC ASSEMBLY AND PARTS LIST

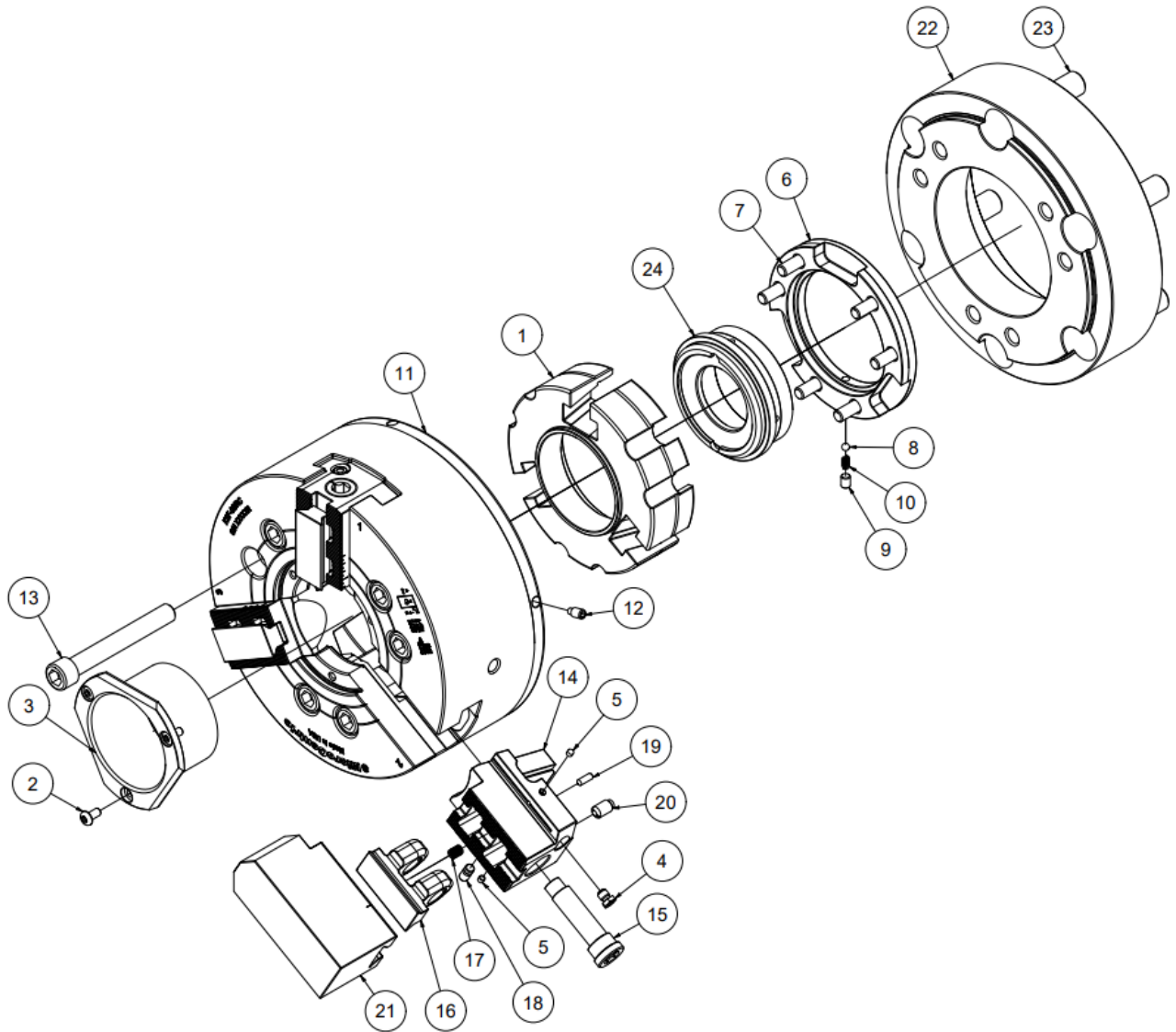

ITEM	QTY	DESCRIPTION
1	1	ACTUATOR
2	3	BUTTON HEAD CAP SCREW
3	1	CENTER SEAL
4	3	GREASE FITTING
5	6	EXPANSION PLUG
6	1	RETAINER
7	6	SOCKET HEAD CAP SCREW
8	1	DETENT BALL
9	1	FLAT POINT SET SCREW
10	1	SPRING
11	1	BODY
12	4	DOG POINT SET SCREW

ITEM	QTY	DESCRIPTION
13	6	SOCKET HEAD CAP SCREW
14	3	MASTER JAW
15	3	CAM BOLT
16	3	DOVETAIL CLAMP
17	3	SPRING
18	3	STOP PIN
19	3	CONE POINT SET SCREW
20	3	BALL PLUNGER
21	3	TOP JAW
22	1	ADAPTER
23	6	SOCKET HEAD CAP SCREW
24	1	DRAW TUBE CONNECTOR

12.2 KSF-08/QC & KSF-10/QC ASSEMBLY AND PARTS LIST

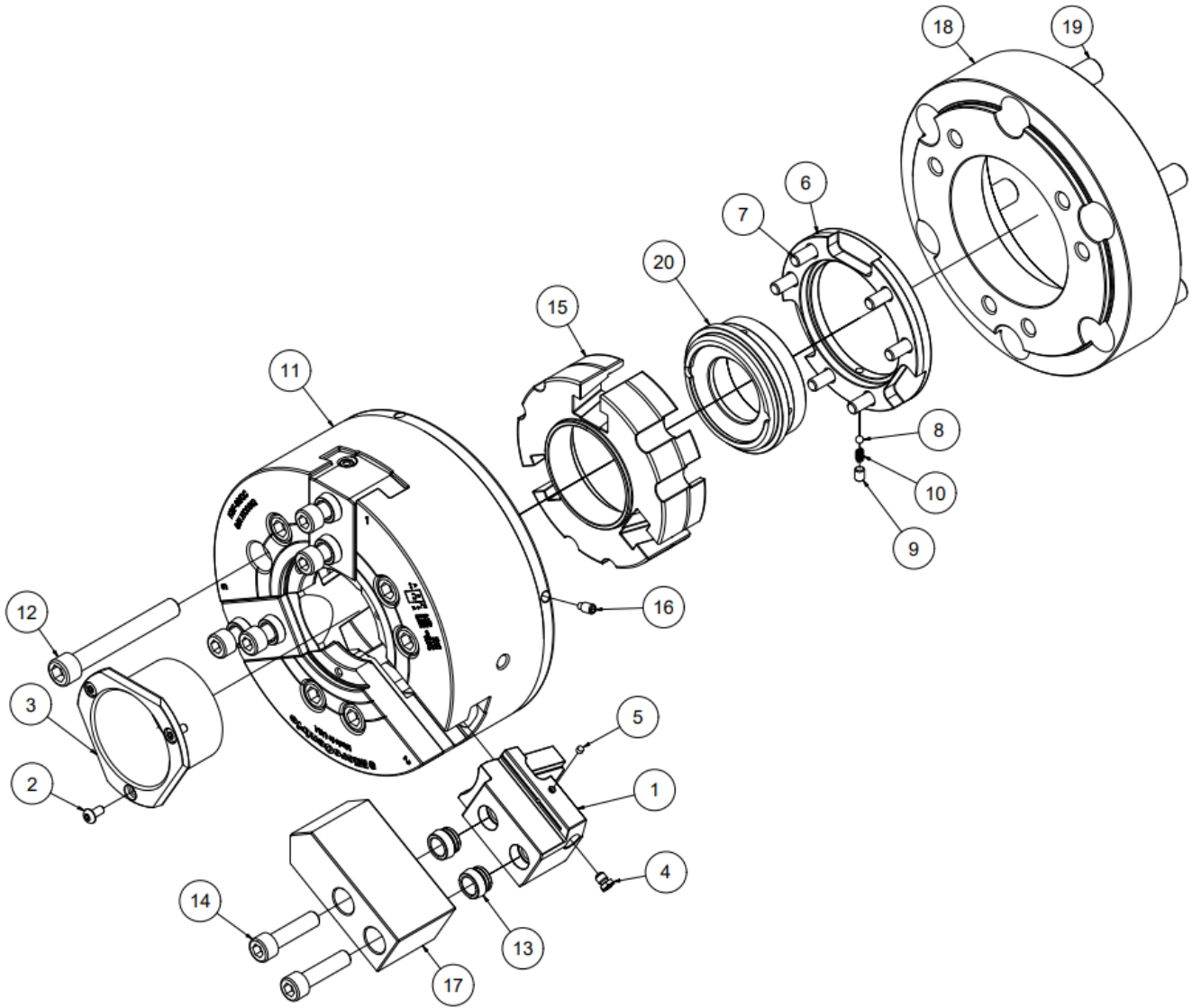

ITEM	QTY	DESCRIPTION
1	3	MASTER JAW
2	3	BUTTON HEAD CAP SCREW
3	1	CENTER SEAL
4	3	GREASE FITTING
5	6	EXPANSION PLUG
6	1	RETAINER
7	6	SOCKET HEAD CAP SCREW
8	1	DETENT BALL
9	1	FLAT POINT SET SCREW
10	1	SPRING

ITEM	QTY	DESCRIPTION
11	1	BODY
12	6	SOCKET HEAD CAP SCREW
13	6	QC BUTTON
14	6	SOCKET HEAD CAP SCREW
15	1	ACTUATOR
16	4	DOG POINT SET SCREW
17	3	TOP JAW
18	1	ADAPTER
19	6	SOCKET HEAD CAP SCREW
20	1	DRAW TUBE CONNECTOR

13.0 KSF CHUCK MAINTENANCE

13.1 LUBRICATING KSF CHUCKS

1. Recommended lubricant: Kluber Altemp QN B 50
2. Apply lubricant with a grease gun (3 to 5 cc) to the grease fitting on each master jaw.
3. After applying lubricant to all fittings, cycle the chuck (open and close the chuck) several times to distribute the lubricant to all sliding surfaces.
4. Wipe away any excess grease which has seeped out of the master jaw slots.

13.2 FREQUENCY OF LUBRICATION

1. KSF chucks should be lubricated at least once daily.
2. Chucks operated at high speed or are exposed to a high volume of water soluble cutting oil should be lubricated several times each day.
3. Chucks which are installed on machines running around the clock, should be lubricated at the start of each shift .

13.3 DISASSEMBLY OF KSF CHUCKS

1. After removing the chuck from the machine, set the chuck (without the adapter plate) on its rear face.
2. Remove the top jaws from the chuck.
3. Remove the center seal by unfastening the (3) button head cap screws.
4. Using (2) blocks of equal height (or parallels), support the front face of the chuck body. Make sure the blocks are clear of the actuator.
5. Remove the assembly of the actuator, retainer, and draw tube connector from the back of the chuck.
6. Once assembly of the actuator, retainer, and draw tube connector has been removed from the back of the chuck, flip the chuck onto its face, and support the chuck body on blocks or parallels.
7. Disassemble the actuator, retainer, and draw tube connector by unfastening the (6) socket head cap screws from the retainer.



WARNING

KSF chucks must be lubricated on a regular basis to maintain long term accuracy and performance. Inadequate lubrication reduces gripping force and affects the chuck's repeating accuracy. Inadequate lubrication will also cause excessive wear and seizure.



CAUTION

KSF chucks should be disassembled, cleaned, lubricated, and reassembled at least once every 6 months or every 100,000 cycles. Chucks that are used to machine cast iron or sintered parts should be disassembled more frequently (at least every 2 to 3 months).

8. Remove the master jaws through the center of the chuck body. If the master jaws are tight, use a brass plug to tap each jaw out of the chuck body.
9. For RC top jaws, remove the ball plunger from the bottom of each master jaw. Also, remove the set screw from the bottom of each master jaw and remove the stop pin. Remove the cam, and allow for the disassembly of the t-nut from the master jaw.

13.4 CLEANING OF KSF CHUCKS

1. After the chuck has been disassembled, remove all sludge and buildup on the sliding surfaces of the chuck body, actuator, and master jaws.
2. Clean off any buildup with fine emery paper.
3. Degrease all components in mineral spirits or other solvent.
4. Remove all residue of the solvent and keep each component clean until reassembly.

13.5 REASSEMBLY OF KSF CHUCKS

1. After all the chuck's components have been thoroughly cleaned, set the chuck face down on blocks (or parallels).
2. Reassemble master jaws. Ensure the ball plunger and stop pin with set screw are fully engaged.
3. Apply a liberal amount of grease such as Kluber Altemp QN B 50 to all surfaces of master jaw no.1. Slide master jaw no. 1 into the jaw slot which is marked slot no.1. The jaw should slide freely into the jaw slot with only hand pressure. If the jaw is tight going into the jaw slot remove the jaw, and make sure any buildup has been removed from both the jaw slot and master jaw. After cleaning, degrease the chuck body and master jaw again with a solvent. Apply lubricant to the master jaw and insert the jaw into the chuck body as outlined above.
4. Repeat this procedure for the other master jaws.
5. Liberally coat the actuator slots and actuator OD with grease. Slide actuator into the chuck body. Guide the 3 slots in the actuators onto the 3 master jaws. The actuator should slide into the chuck body freely, however, it may be necessary to tap the rear face of the actuator with a soft hammer to bring the assembly fully into the chuck body. Tap the rear face of the piston in a circular motion to prevent the piston from cocking.
6. Assemble the draw tube connector and the retainer to the actuator. Tighten the (6) socket head cap screws alternatively and equally to the recommended torque specifications given in Section 4.
7. Turn the chuck body over and support it on the blocks (or parallels) used to disassemble the chuck.
8. Replace the center seal on the face of the chuck. Secure center seal with (3) button head cap screws.
9. Reassemble top jaws as seen in Section 10 for RC top jaws or Section 11 for QC top jaws.

IMPORTANT

All components must be thoroughly cleaned and degreased before reassembly. Perform all assembly work on a clean bench in clean surroundings to prevent dirt and other contaminants from getting into the chuck.



CAUTION

When reassembling KSF chucks make sure each master jaw is mounted into the jaw slot with a corresponding number.

14.0 TROUBLE SHOOTING GUIDE

If your KSF chuck malfunctions, immediately stop the machine and refer to this trouble shooting guide for possible causes and ways to remedy the problem.

PROBLEM	POSSIBLE CAUSE	SUGGESTED REMEDY
The chuck does not operate.	A component inside the chuck (master jaw or actuator) is broken.	Disassemble chuck and contact MicroCentric for replacement or repair of the component or chuck.
	The master jaw slides or actuators are seized.	Disassemble the chuck to free the seized components by cleaning the chuck and removing buildup that has embedded itself onto the chuck's components and lubricate the chuck.
The master jaws do not stroke fully.	Swarf or dirt has built up inside the chuck.	Disassemble, clean, and lubricate the chuck.
	Improper assembly.	Ensure all parts have been reassembled correctly.
	The draw tube connector or draw tube is loose.	First check that the draw tube connector is fully threaded onto the draw tube. If the problem persists remove the chuck and tighten the draw tube onto the hydraulic actuator.
Workpiece slips.	Insufficient master jaw stroke.	Rebore top jaws so that the workpiece is clamped in the middle of the chuck's total jaw stroke.
	Insufficient clamping force.	Increase the hydraulic pressure to the cylinder within recommended limits.
	Machined clamping diameter in top jaw does not match workpiece diameter.	Rebore top jaws accordingly.
	Cutting force is too high.	Reduce cutting force.
	Insufficient lubrication to the chuck.	Lubricate the chuck according to the schedule and procedure outlined in Section 13.1 & 13.2.
	Spindle speed is too high.	Reduce spindle speed.
Excessive Vibration	Unequal weight distribution.	Counterbalance as required.
Excessive workpiece runout (concentricity) after machining.	OD of chuck is running out, (mounting screws not tight).	Indicate OD of chuck and true chuck to within specifications given in Section 9.0. Also make sure mounting screws are tightened properly.
	Chips, dirt, or other foreign material is embedded in clamping surface of top jaw.	Remove foreign material and/or rebore top jaws.
	Mounting screws of top jaws have not been adequately tightened.	Tighten mounting screws to torque specifications given in Section 4.0.
	Top jaws have not been properly machined (loaded).	Check that the loading ring or plug is not being deformed due to high clamping force. Review procedures outlined in Section 7.4.
	Top jaw is deformed during clamping due to excessive height and/or excessive clamping force.	Review the design of the top jaw, reducing the height of the jaw and lowering draw tube force.
	Workpiece is deformed during clamping by excessive clamping force.	Reduce draw tube force. Also evaluate the design of the top jaws to reduce jaw height and jaw mass to reduce effects of centrifugal force.



MicroCentric Corp • 25 So. Terminal Drive, Plainview, NY 11803 USA
Tel: 1-516-349-7220 • Fax: 1-516-349-9354 • e-mail: sales@microcentric.com

www.microcentric.com